

Disassembly

You will need a flat-head screwdriver to unlock the side and end rail connectors. Follow the steps below to unlock all four corner connectors.

- 1 Put the screwdriver into the hole on the outside of the end rail opening (Part B).

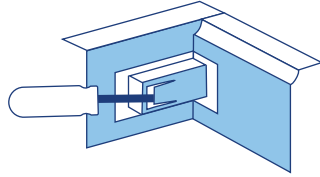

- 2 Use the screwdriver to lift the front latch and release the connection between the rails. At the same time, pull the side rail peg (Part A) out of the end rail opening (Part B).

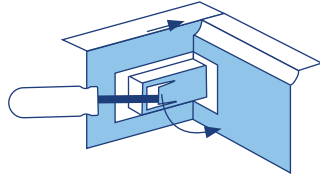

amerisleep.com

Amerisleep Mattress Foundation Assembly

If you are experiencing issues with setup, please call (800) 500-4233
or email cs@amerisleep.com



Assembly

The Amerisleep foundation provides your Amerisleep mattress with excellent support, making them a perfect pair. This guide will help you assemble your foundation in minutes, and you will not need any tools.

Contents:

- 2x Side rails
- 2x End rails
- 2x Slat packs
- 1x Center support rail (2x for King & Cal King)
- 7x Wooden legs (8x for King & Cal King)

- 1 Connect both side rails to one of the end rails—either one is fine—by inserting the “pegs” from the side rail (Part A) into the openings in the end rail (Part B).

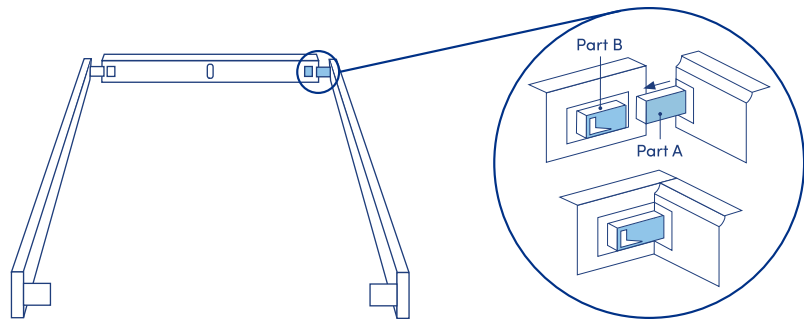

- 2 Insert one end of the center support rail into the gap at the middle of the end rail. When done properly, it will “click” into place.

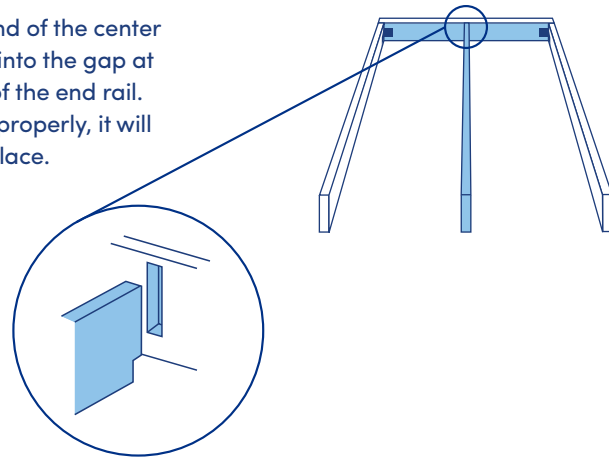

- 3 Repeat steps 1 and 2 to connect the other end rail. When you're finished, all four sides of the foundation should be securely connected, with the center support rail firmly in place down the middle.

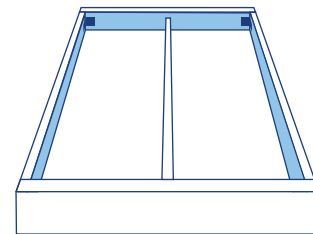

- 4 **Note:** Skip this step if you're using an existing bed frame. Flip over the foundation so the bottom side is facing up, then turn and tighten the wooden legs into the nut holes by hand. When you're done, turn the foundation back over so the feet are on the ground.

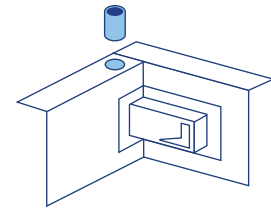

- 5 Unroll both slat packs across the top of the foundation. To securely fix them in place, connect the holes at the corners of each slat pack to the wooden dowels along the ledge of the side rails.

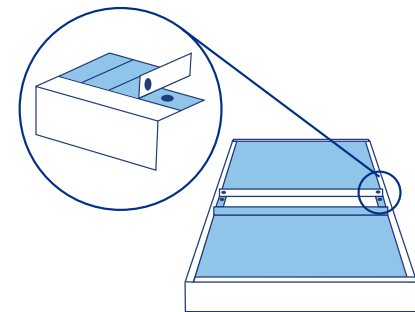

- 6 Place your Amerisleep mattress on top and enjoy!

